



國喬石油化學股份有限公司
GRAND PACIFIC PETROCHEMICAL CORPORATION

established	1973
capital	NT 9.27 billion
revenue	NT 15.6 billion (2019Q1-Q3)
employee	380 (2019Q3)

Disclaimer

The forward-looking statements contained in this presentation are subject to risks and uncertainties and actual results may differ materially from those expressed or implied in these forward-looking statements.

Grand Pacific Petrochemical Corporation makes no representation or warranty as to the accuracy or completeness of these forward-looking statements and nor does Grand Pacific Petrochemical Corporation undertake any obligation to update any forward-looking statements, whether as a result of new information or future events.

Outline

- Upstream and downstream products
- Market review and prospect
- Financial results

Upstream and downstream products

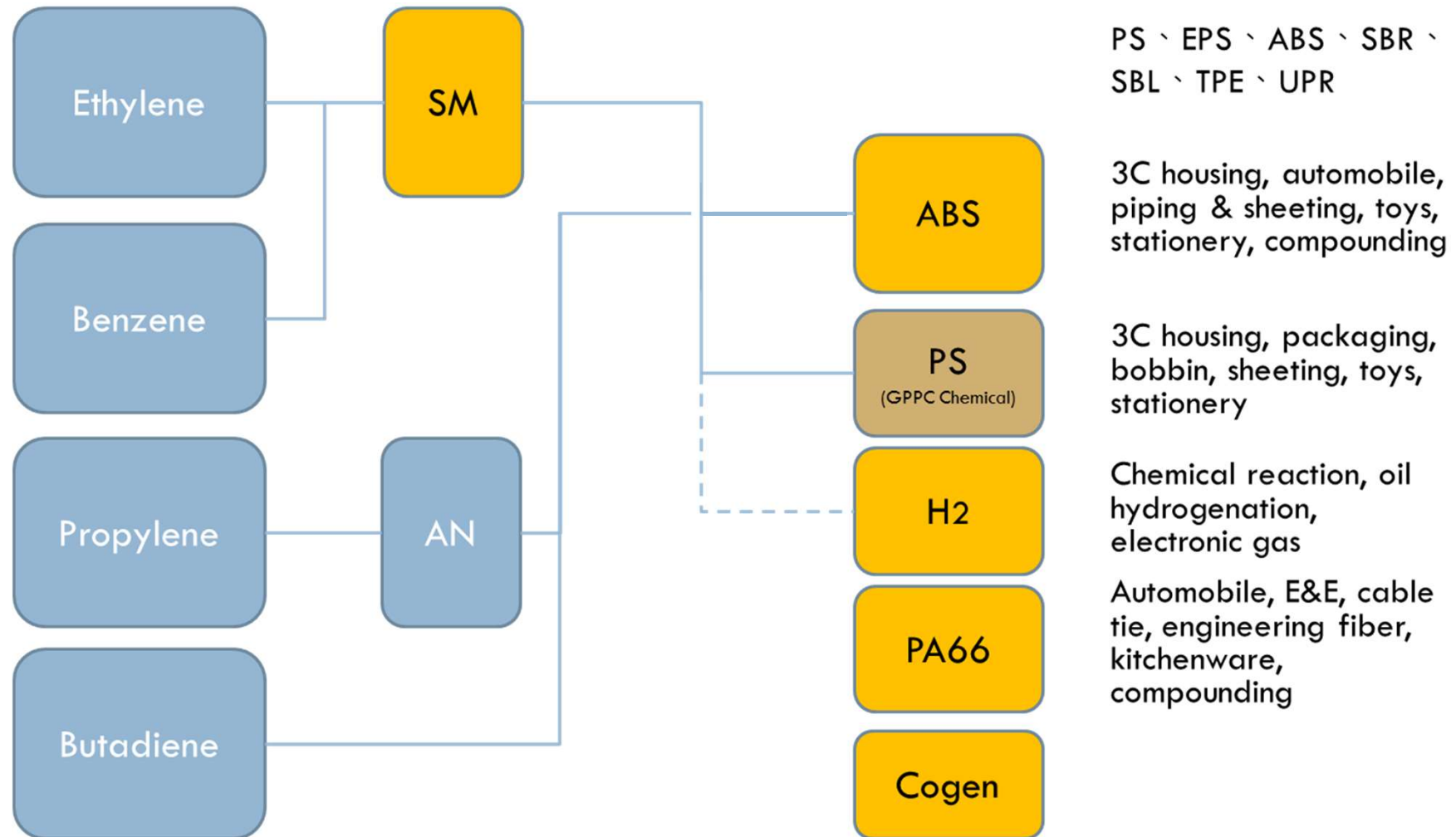

Sales volume(MT)

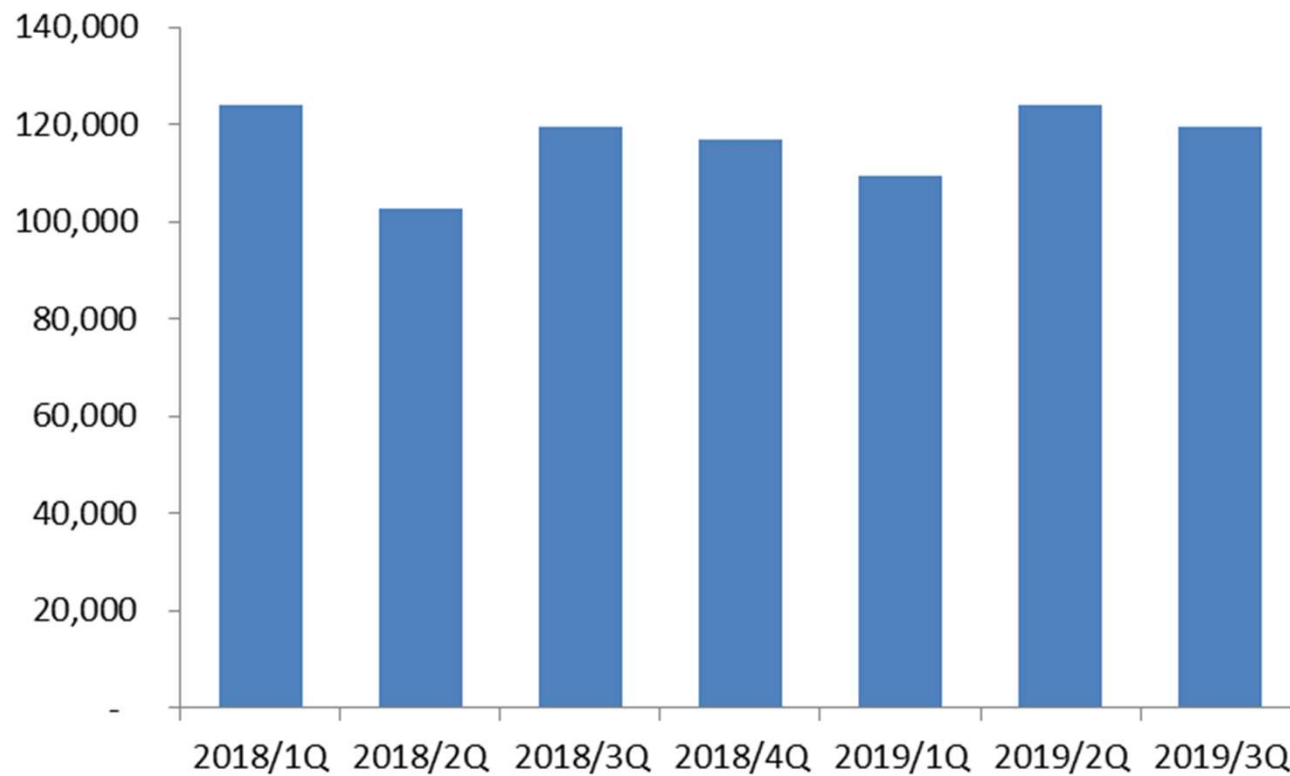

Cogen products and hydrogen excluded

Asian price trend - styrene

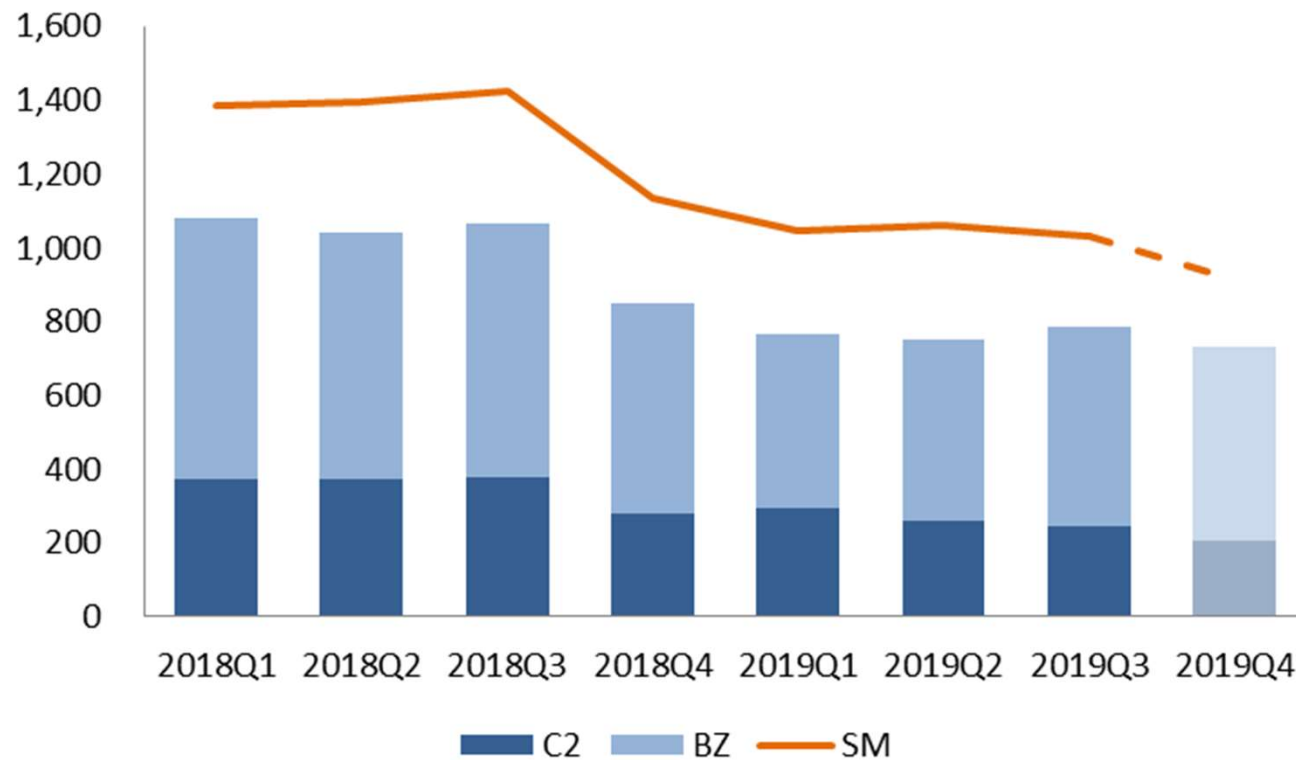

Asian price trend - ABS

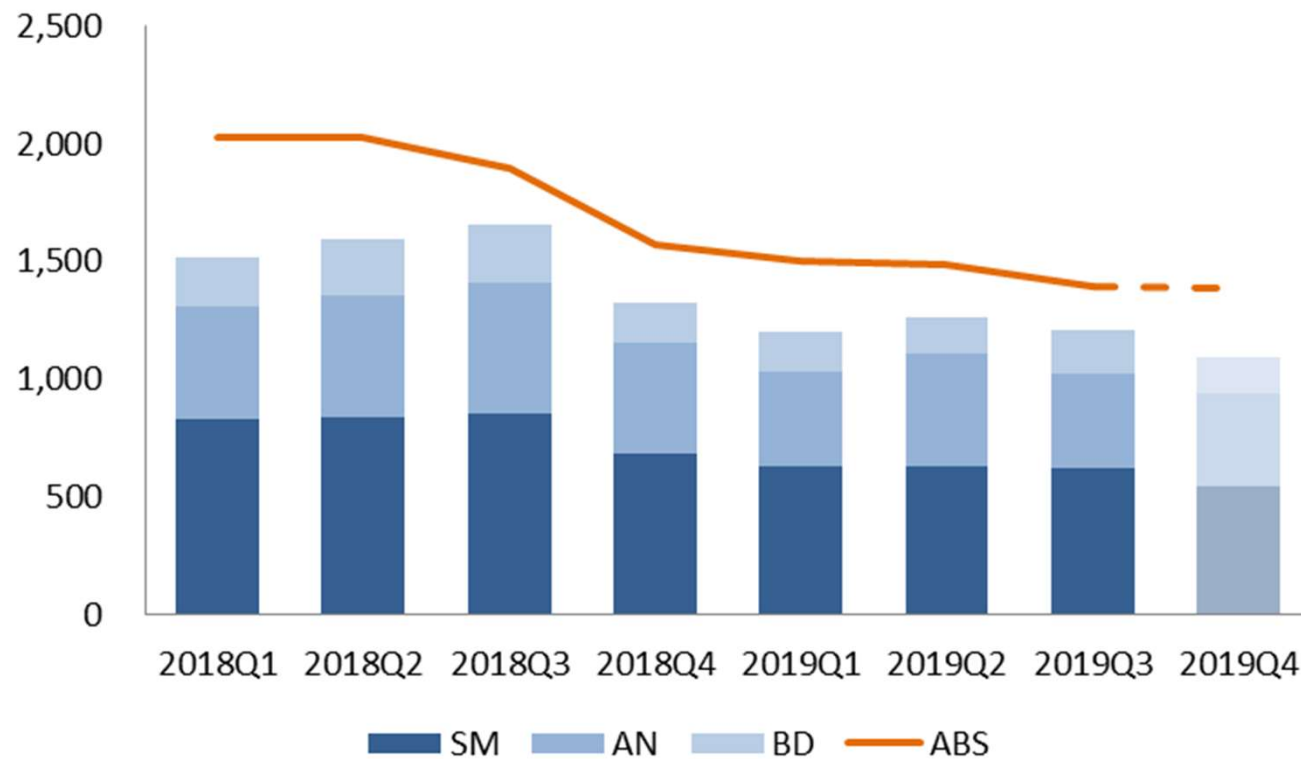

Asian price trend – PA66

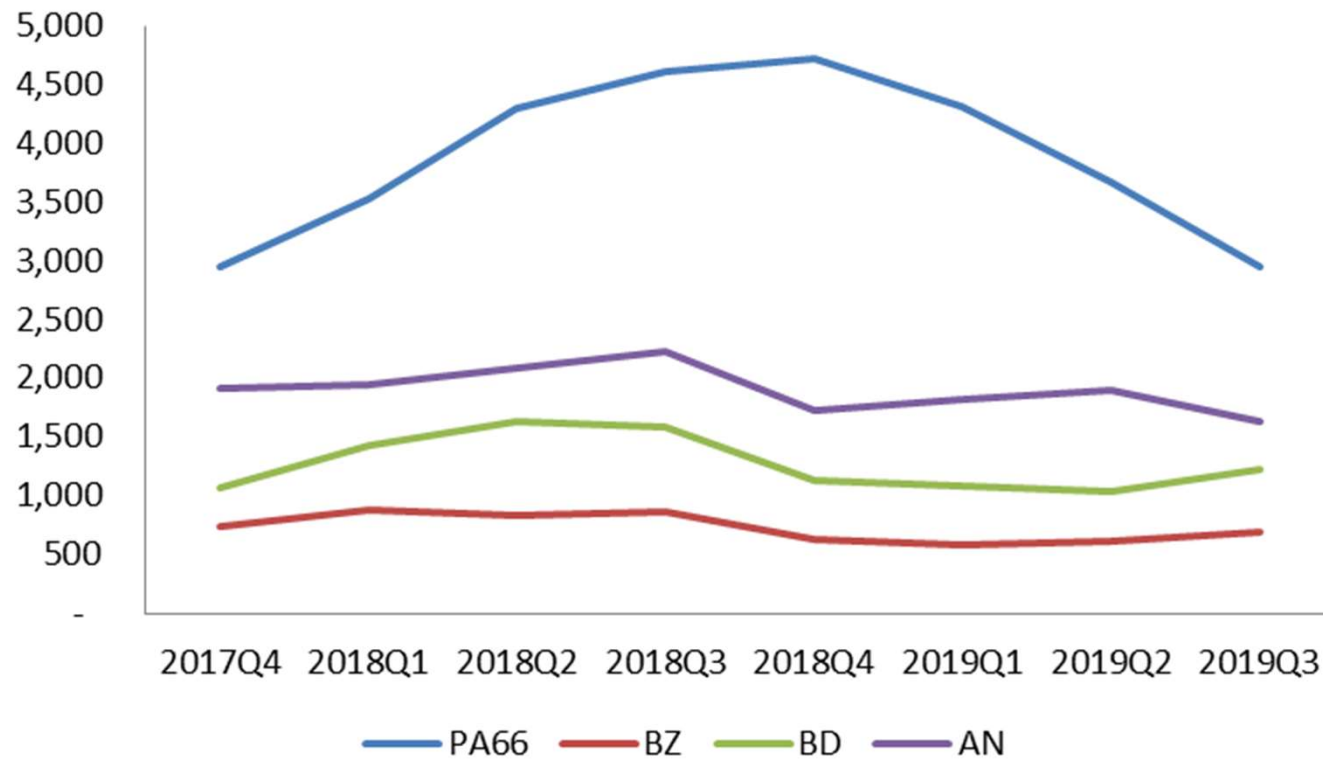

Imp/Exp Change after China's ADD on styrene

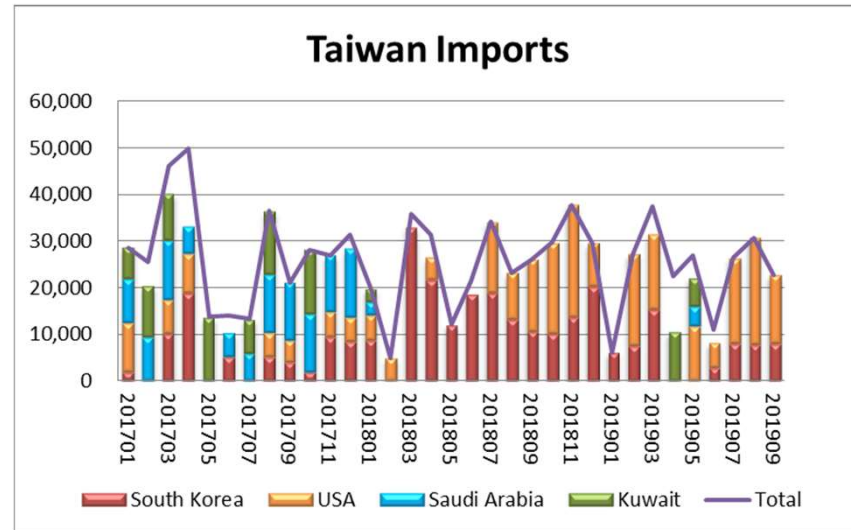
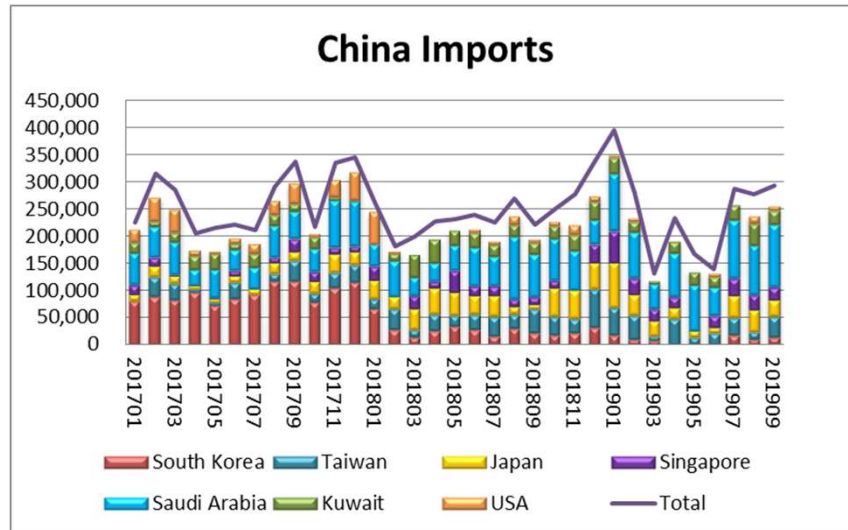

Asian styrene: capacity addition

Company	Location	Capacity kTA	Timing		
			A	B	C
CSPC	惠州	640	2020	2H2020	
恆力	大連	720	'21-22	'19-20	
浙江石化	舟山	1,200	2021	'19-20	
中信國安瑞華	荷澤	200		1H2020	2019
萬華	煙台	650	2020	2020	2022
中化	泉州	450	2021	'20-21	
古雷	古雷	600	2022	'20-21	
浙江石化	舟山	600	2023	'22~	
渤化	天津	450	2020	2020	
阿貝爾II	泰興	500		'22~	
山東利華益	利津	720			2021
山東齊旺達	淄博	500			2020
山東榮華	濱州	200			2020
寶萊	盤錦	360			2020
華泰盛富	寧波	300	2021		
.....
Ineos Styrolution	US Gulf	850-900?		'22~	

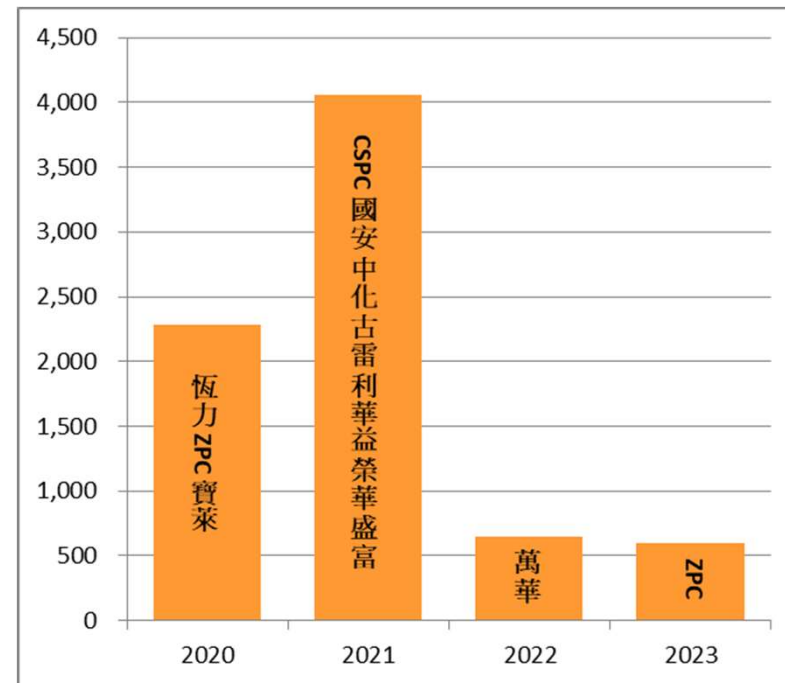

Styrene balance in China

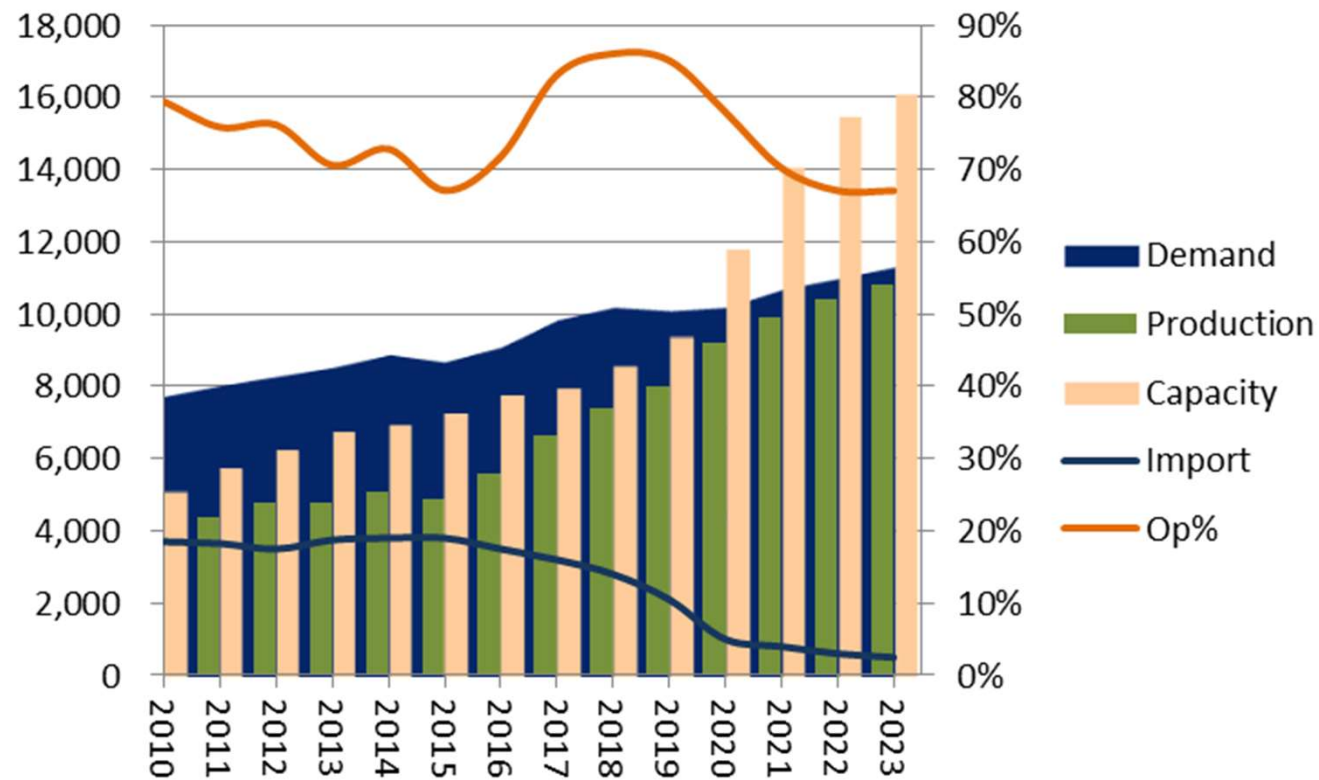

Financial results



Consolidated Statements of Income

(NT\$ BN)

Item \ Period	FY16	FY17	FY18	9M18	9M19
Net Revenue	19,918	23,351	24,741	19,019	15,575
Cost of Revenue	16,494	19,557	20,686	15,571	13,337
Gross Profit	3,424	3,794	4,055	3,448	2,238
gross profit ratio	17%	16%	16%	18%	14%
Operating Expenses	1,257	1,310	1,316	1,018	954
Income from Operations	2,167	2,484	2,739	2,430	1,284
operating income ratio	11%	11%	11%	13%	8%
Non-operating Income and Expenses	917	1,699	1,318	1,286	1,080
Income Before Income Tax	3,084	4,183	4,057	3,716	2,364
Income Tax Expenses	505	735	906	843	518
Net Income	2,579	3,448	3,151	2,873	1,846
net income ratio	13%	15%	13%	15%	12%
Net Income Attributable to :					
-Shareholders of the Parent	2,400	3,289	2,960	2,726	1,775
-Noncontrolling Interests	179	159	191	147	71
Earnings per Share (NT\$)	2.65	3.64	3.26	3.00	1.95

Revenue structure

9M19

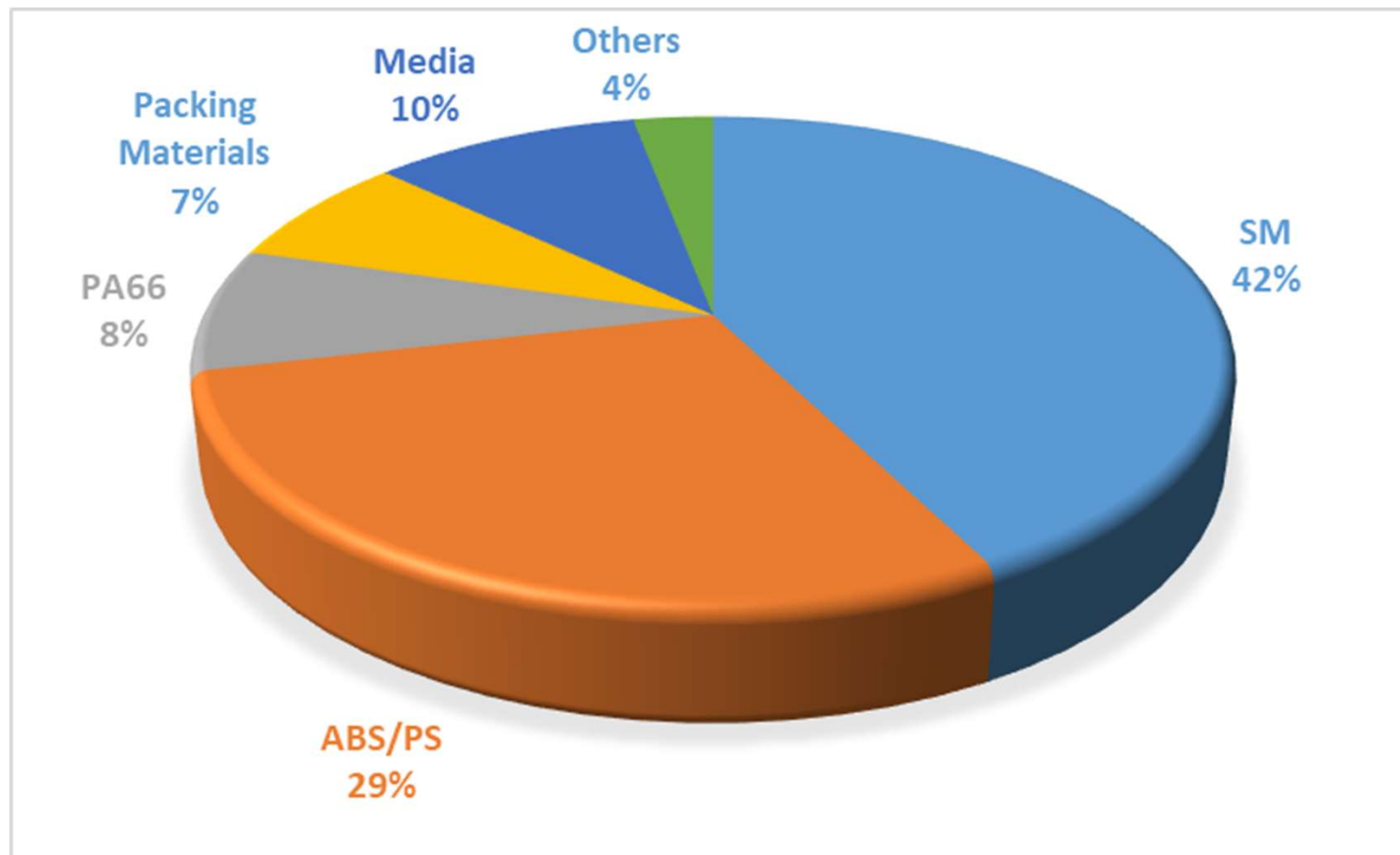

Financial Analysis

Item \ Period	2016	2017	2018	9M19
Debt ratio (%)	16.63	16.13	14.20	13.52
Current ratio (%)	269.18	302.59	377.19	456.86
Quick ratio (%)	210.47	236.61	306.21	384.96
A/R turnover (times)	7.68	7.39	7.87	7.41
A/R turnover (days)	47	49	46	49
Inventory turnover (times)	9.98	10.65	10.33	9.68
Days sales outstanding	36	34	35	38
Return on equity (%)	12.97	15.55	12.83	9.37